

型号说明 / MODEL ILLUMINATE

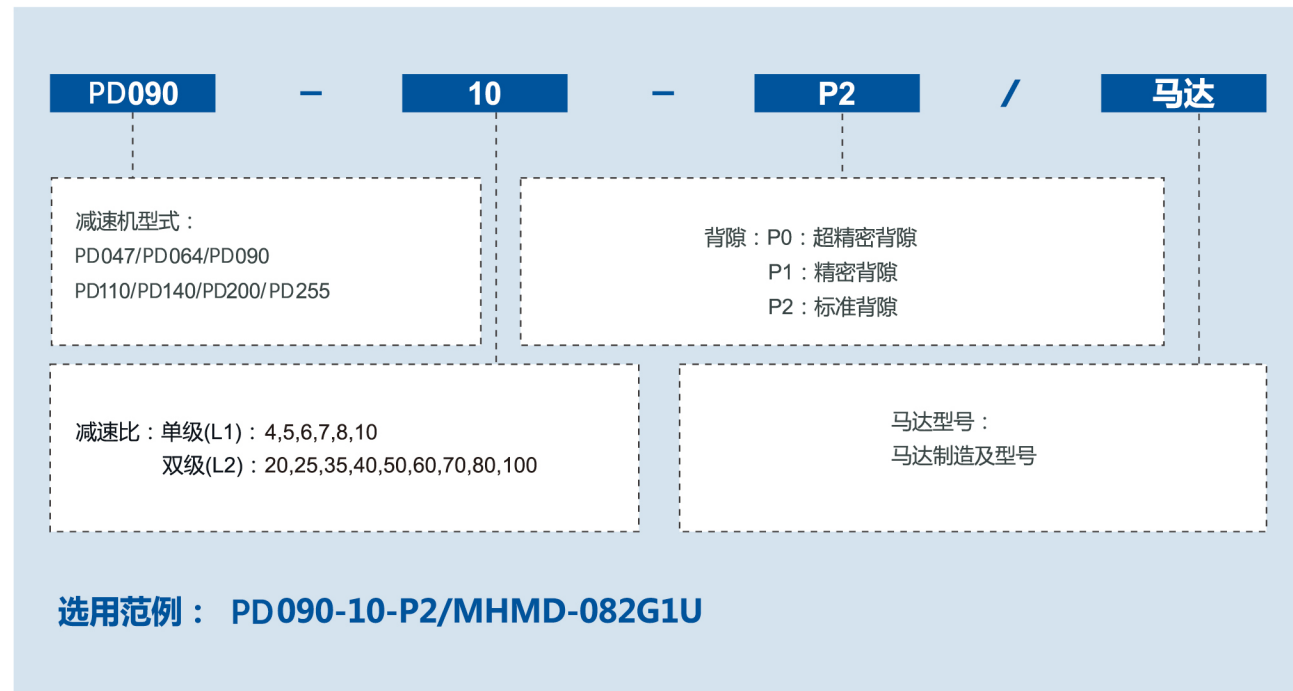

减速机性能资料 / GEAR BOX PERFORMANCE INFORMATION

规格	级数	减速比 ¹	PD 047	PD064	PD090	PD110	PD140	PD200	PD255	
额定输出力矩 T _{2N}	1	4	19	48	130	270	560	1,100	1,700	
		5	22	60	160	330	650	1,200	2,000	
		6	-	55	150	310	600	-	-	
		7	19	50	140	300	550	1,100	1,800	
		8	17	45	120	260	500	1,000	1,600	
		10	14	40	100	230	450	520	1,220	
		2	20	19	48	130	270	560	1,100	1,700
			25	22	60	160	330	650	1,200	2,000
			35	22	60	160	330	650	1,200	2,000
			40	22	48	130	270	560	1,200	2,000
	最大输出力矩 T _{2B}	Nm	50	22	60	160	330	650	1,200	2,000
			60	-	55	150	310	600	-	-
			70	19	50	140	300	550	1,100	1,800
			80	-	45	120	260	500	-	-
100			14	40	100	230	450	520	1,220	
100			14	40	100	230	450	520	1,220	
最大输入转速 n _{1B}	rpm	1,2	4~100	5,000	5,000	4,000	4,000	3,000	3,000	2,000
超精密背隙 P0	arcmin	1	4~100	-	-	≤1	≤1	≤1	≤1	
精密背隙 P1	arcmin	2	4~10	-	-	≤3	≤3	≤3	≤3	
		1	20~100	≤3	≤3	≤3	≤3	≤3	≤3	
标准背隙 P2	arcmin	2	4~10	≤5	≤5	≤5	≤5	≤5	≤5	
		1	20~100	≤5	≤5	≤5	≤5	≤5	≤5	
扭转刚性	Nm/arcmin	1,2	20~100	7	13	31	82	151	440	1,006
最大弯曲力矩 M _{2KB} ²	Nm	1,2	4~100	42.5	125	235	430	1,300	3,064	5,900
容许径向力 F _{2B} ²	N	1,2	4~100	1,080	2,110	2,310	4,800	6,200	5,450	10,600
使用寿命	hr	1,2	4~100	20,000*						
效率 η	%	1	4~10	≥97%						
		2	20~100	≥94%						
重量	kg	1	4~10	0.7	1.2	3.0	5.6	11.9	31.6	56.1
		2	20~100	1.0	1.6	3.7	7.3	15.9	36.9	70.4
使用温度	°C	1,2	4~100	-10°C~+90°C						
润滑		1,2	4~100	合成润滑油脂						
防护等级		1,2	4~100	IP65						
安装方向		1,2	4~100	任意方向						
噪音值 (n ₁ =3000rpm)	dB	1,2	4~100	≤56	≤58	≤60	≤63	≤65	≤67	≤70

减速机转动惯量

规格	级数	减速比 ¹	PD 047	PD064	PD090	PD110	PD140	PD200	PD255	
转动惯量 J ₁	1	4	0.03	0.14	0.51	2.87	7.54	25.03	58.31	
		5	0.03	0.13	0.47	2.71	7.42	23.29	53.27	
		6	-	0.13	0.45	2.65	7.25	-	-	
		7	0.03	0.13	0.45	2.62	7.14	22.48	50.97	
		8	0.03	0.13	0.45	2.58	7.07	22.48	50.97	
		10	0.03	0.13	0.44	2.57	7.03	22.51	50.56	
		2	20	0.03	0.03	0.13	0.47	2.71	7.42	23.29
			25	0.03	0.03	0.13	0.47	2.71	7.42	23.29
			35	0.03	0.03	0.13	0.47	2.71	7.42	23.29
			40	0.03	0.03	0.13	0.44	2.57	7.03	22.51
	kg·cm ²	50	0.03	0.03	0.13	0.44	2.57	7.03	22.51	
		60	-	0.03	0.13	0.44	2.57	-	-	
		70	0.03	0.03	0.13	0.44	2.57	7.03	22.51	
		80	-	0.03	0.13	0.44	2.57	-	-	
100		0.03	0.03	0.13	0.44	2.57	7.03	22.51		

1. 减速比 (i=N_{in}/N_{out})
* 连续运转降低使用寿命二分之一。

2. 输出转速 100rpm 时，作用于输出轴中心位置。

外形尺寸图表 / OUTLINE DIMENSION SHEET

PD-047-L1

输入端/INPUT

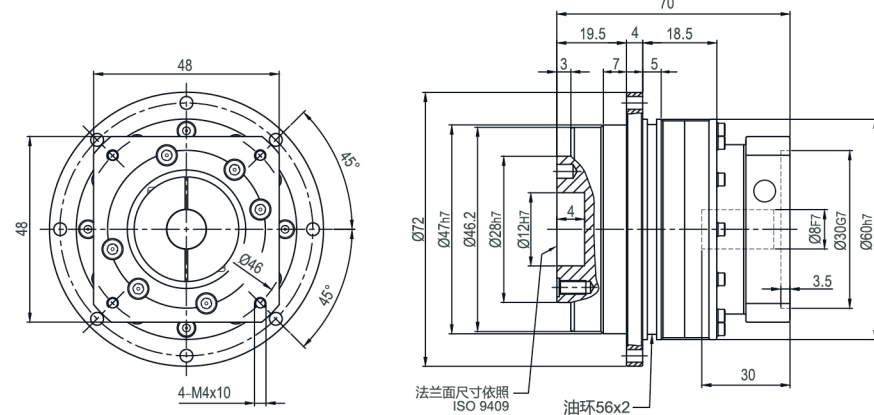

输出端/OUTPUT

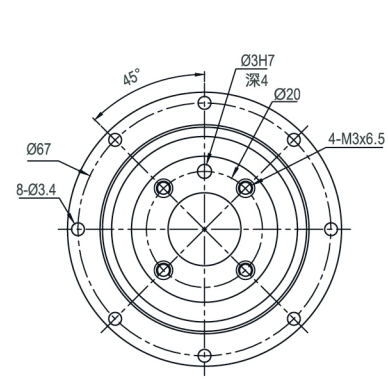

PD-047-L2

输入端/ INPUT

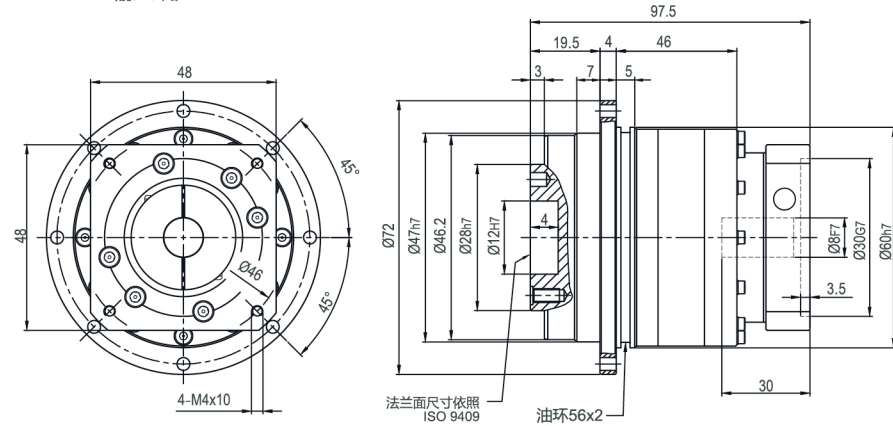

输出端 /OUTPUT

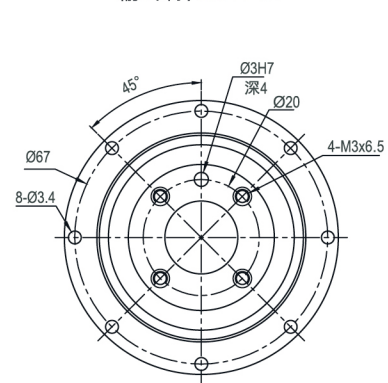

*输入马达连接板之尺寸,可根据客户要求单独定做。
*The input motor specific dimensions could be customised.

外形尺寸图表 / OUTLINE DIMENSION SHEET

PD-064D(M1)-L1

输入端/ INPUT

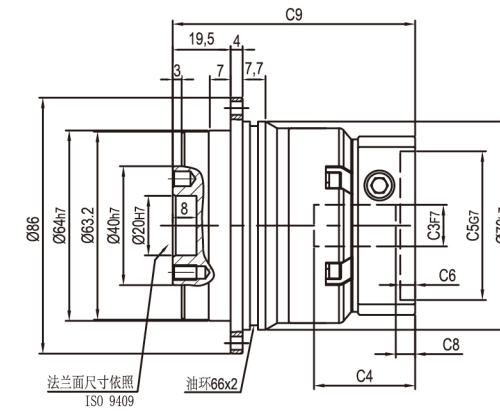
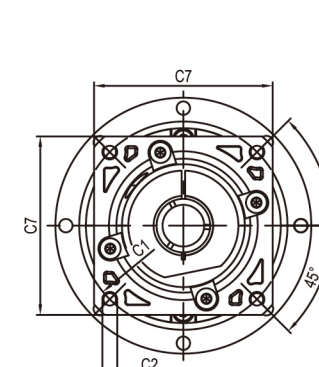

输出端/OUTPUT

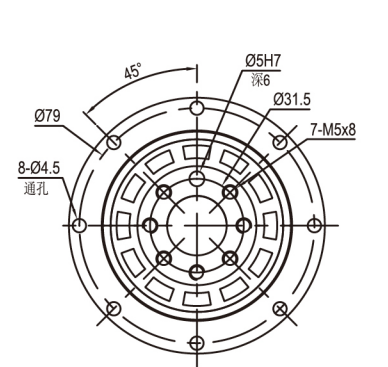

PD-064D(M1)-L2

输入端/ INPUT

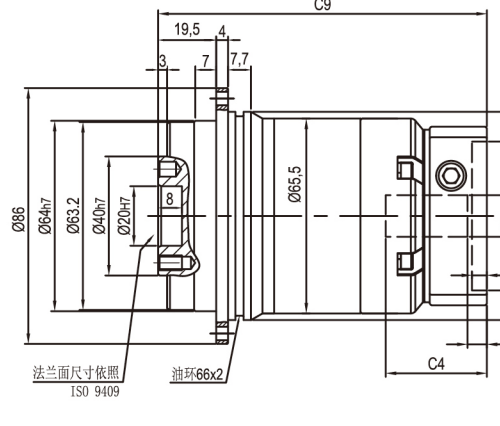
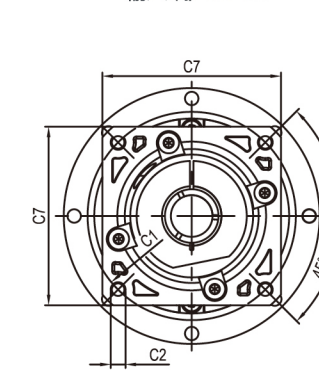

输出端/OUTPUT

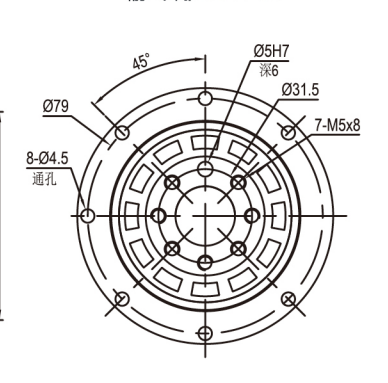

尺寸	C1	C2	C3	C4	C5	C6	C7	C8	C9
PD-064D-L1	Ø66.7	4-M4x10	Ø8	34	Ø38.1	5	60	5.5	81.5
PD-064D-L2									110.5
PD-064D-L1	Ø70	4-M4x10,4-M5x12	Ø11,Ø14	34	Ø50	5	60	5.5	81.5
PD-064D-L2									110.5
PD-064M1-L1	Ø90	4-M5x12,4-M6x14	Ø19	42	Ø70	6.5	80	12	88
PD-064M1-L2									117

* C1~C7是公制标准马达连接板之尺寸,可根据客户要求单独定做。
* C1~C7are motor(metric standard) specific dimensions, which could be customised.
• D:常规孔,M1:极限孔
• D: Conventional Hole, M1: Limit Hole

外形尺寸图表 / OUTLINE DIMENSION SHEET

PD-090D(M1)-L1

输入端/INPUT

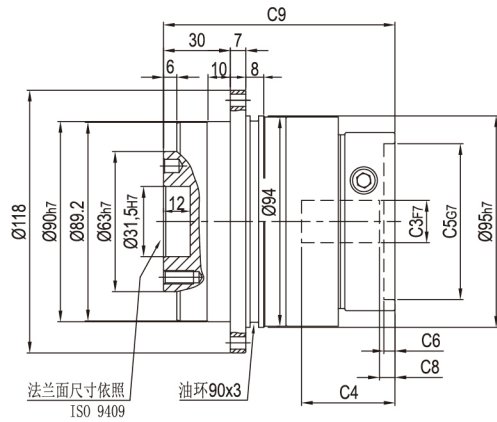
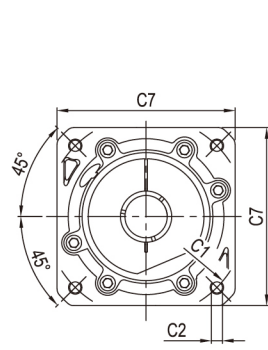

输出端/ OUTPUT

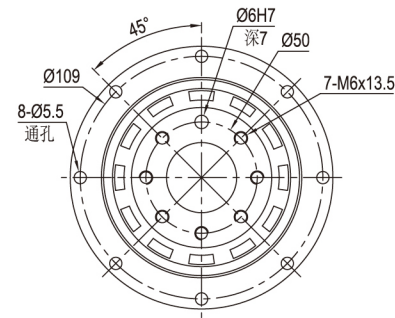

PD-090D(M1)-L2

输入端/ INPUT

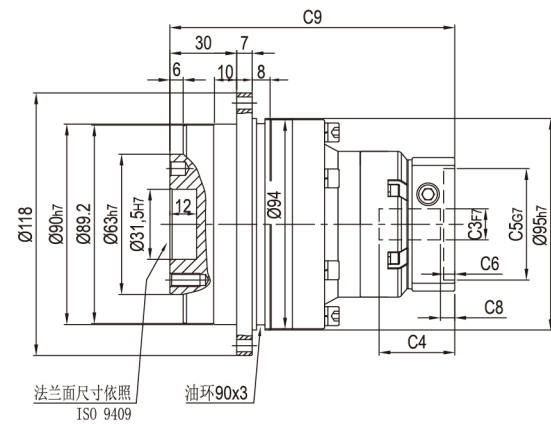
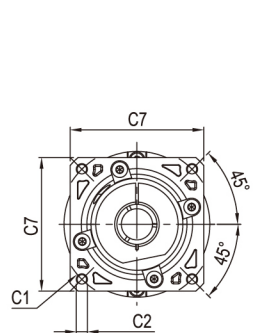

输出端/OUTPUT

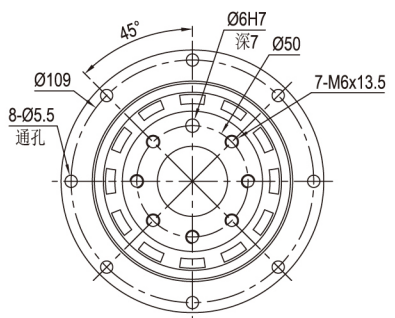

外形尺寸图表 / OUTLINE DIMENSION SHEET

PD-110D(M1)-L1

输入端/ INPUT

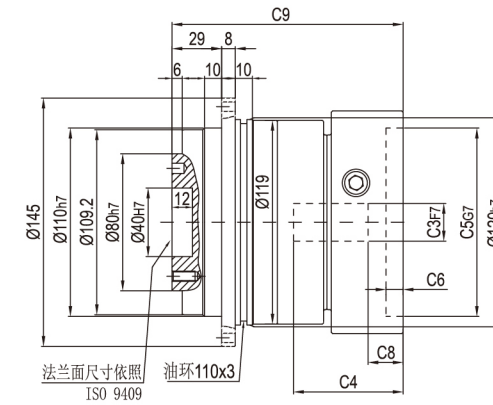
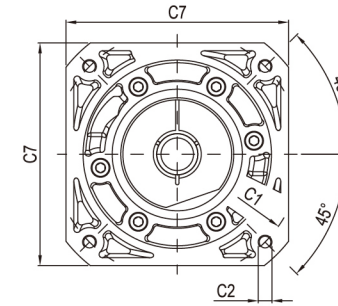

输出端/OUTPUT

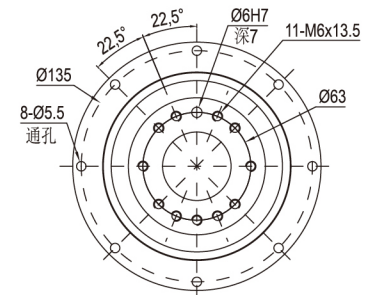

PD-110D(M1)-L2

输入端/ INPUT

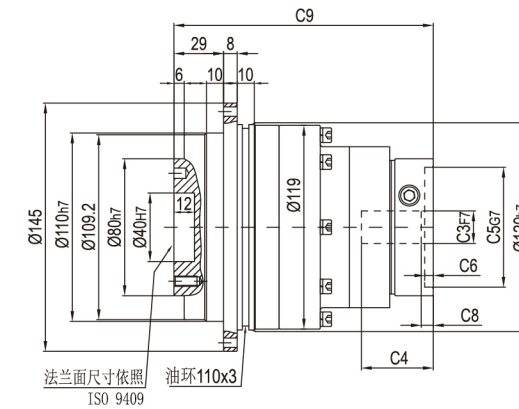
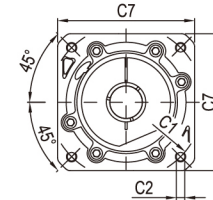

输出端/OUTPUT

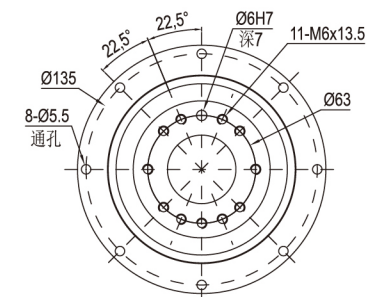

尺寸	C1	C2	C3	C4	C5	C6	C7	C8	C9
PD-090D-L1	Ø90	4-M5x12, 4-M6x14	Ø19	42	Ø70	6.5	80	7	104
	Ø100	4-M6x14	Ø16	42	Ø80	6.5	86	6	104
PD-090M1-L1	Ø115	4-M8x20	Ø19,Ø22	56.5	Ø95	8	100	16.5	119.5
	Ø145	4-M8x20	Ø19,Ø22,Ø24	59	Ø110	11	130	19	122
PD-090D-L2	Ø66.7	4-M4x10	Ø8	34	Ø38.1	5	60	5.5	128
	Ø70	4-M4x10, 4-M5x12	Ø11,Ø14	34	Ø50	5	60	5.5	128
PD-090M1-L2	Ø90	4-M5x12, 4-M6x14	Ø19	42	Ø70	6.5	80	12	134.5
	Ø100	4-M6x14	Ø16	42	Ø80	6.5	86	11	134.5

* C1~C7是公制标准马达连接板之尺寸,可根据客户要求单独定做。
* C1~C7are motor(metric standard) specific dimensions, which could be customised.
* D:常规孔,M1:极限孔
* D: Conventional Hole, M1: Limit Hole

尺寸	C1	C2	C3	C4	C5	C6	C7	C8	C9
PD-110D-L1	Ø145	4-M8x20	Ø19,Ø22,Ø24	64	Ø110	10	130	19.5	135
PD-110M1-L1	Ø200	4-M12x28	Ø35	81	Ø114.3	10	180	28	152.5
PD-110D-L2	Ø90	4-M5x12, 4-M6x14	Ø19	42	Ø70	6.5	80	7	151.5
	Ø100	4-M6x14	Ø16	42	Ø80	6.5	86	6	151.5
PD-110M1-L2	Ø115	4-M8x20	Ø19,Ø22	56.5	Ø95	8	100	16.5	167
	Ø145	4-M8x20	Ø19,Ø22,Ø24	59	Ø110	11	130	19	169.5

* C1~C7是公制标准马达连接板之尺寸,可根据客户要求单独定做。
* C1~C7are motor(metric standard) specific dimensions, which could be customised.
* D:常规孔,M1:极限孔
* D: Conventional Hole, M1: Limit Hole

外形尺寸图表 / OUTLINE DIMENSION SHEET

PD-140D(M1)-L1

输入端/INPUT

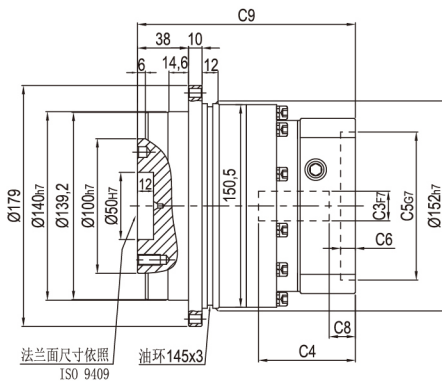
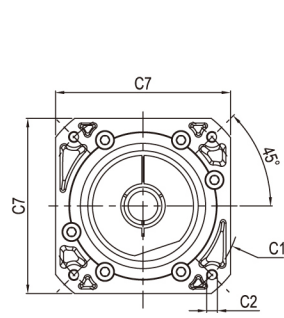

输出端/OUTPUT

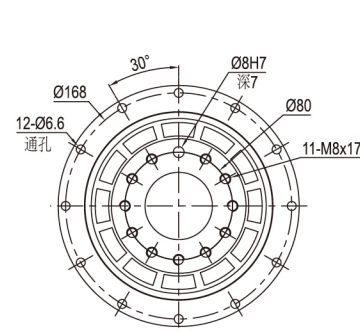

PD-140D(M1)-L2

输入端/INPUT

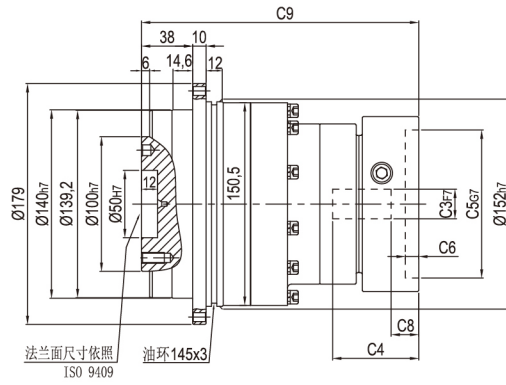
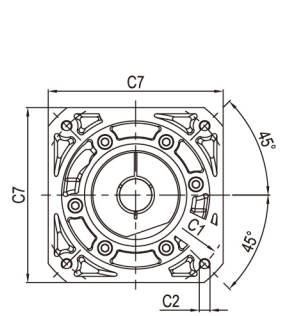

输出端/OUTPUT

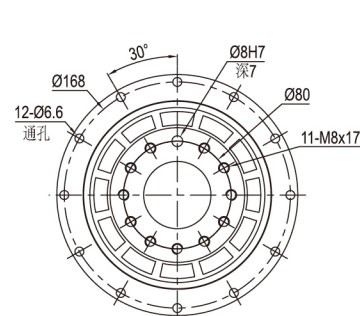

外形尺寸图表 / OUTLINE DIMENSION SHEET

PD-200-L1

输入端/INPUT

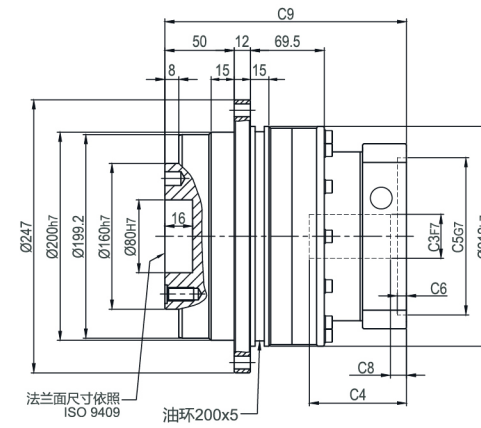
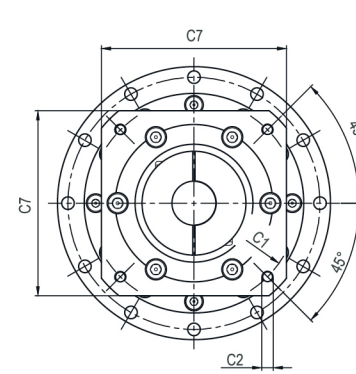

输出端/OUTPUT

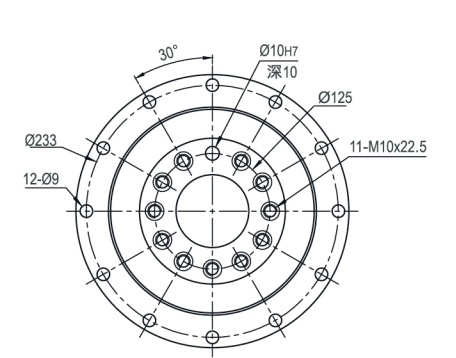

PD-200-L2

输入端/INPUT

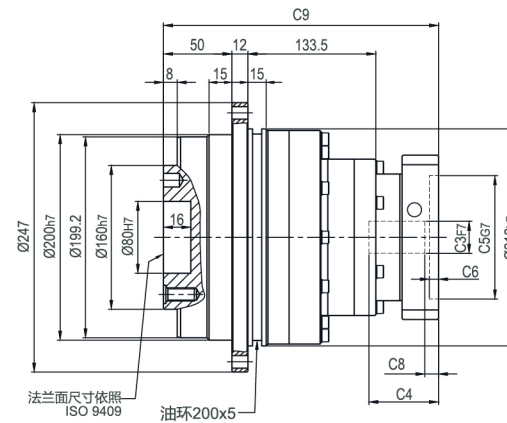
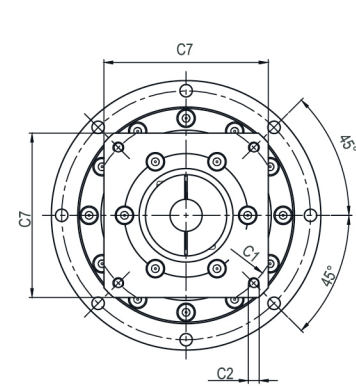

输出端/OUTPUT

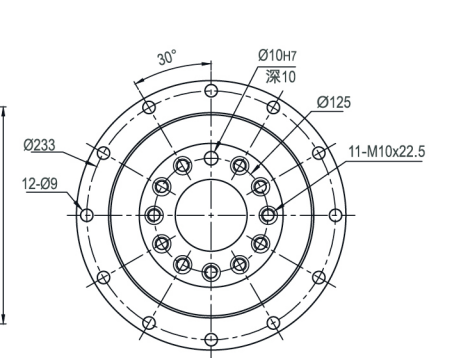

尺寸	C1	C2	C3	C4	C5	C6	C7	C8	C9
PD-140D-L1	Ø145	4-M8x20	Ø22,Ø24	72	Ø110	11	130	19.5	162
	Ø200	4-M12x28	Ø35	81.5	Ø114.3	8	180	25	172
PD-140D-L2	Ø145	4-M8x20	Ø19,Ø22,Ø24	64	Ø110	10	130	19.5	206
PD-140M1-L2	Ø200	4-M12x28	Ø35	81	Ø114.3	10	180	28	223.5

- * C1~C7是公制标准马达连接板之尺寸,可根据客户要求单独定做。
- * C1~C7are motor(metric standard) specific dimensions, which could be customised.
- * D:常规孔, M1:极限孔
- * D: Conventional Hole, M1: Limit Hole

尺寸	C1	C2	C3	C4	C5	C6	C7	C8	C9
PD-200-L1	Ø165	4-M10x25	Ø32	86	Ø130	6	168	8.5	199.5
	Ø200	4-M12x28	Ø35	86	Ø114.3	6	180	8.5	199.5
PD-200-L2	Ø145	4-M8x25	Ø22,Ø24	75	Ø110	11	130	19	249.5
	Ø200	4-M12x30	Ø35	83	Ø114.3	8	180	28	257.5

- * C1~C7是公制标准马达连接板之尺寸,可根据客户要求单独定做。
- * C1~C7are motor(metric standard) specific dimensions, which could be customised.

外形尺寸图表 / OUTLINE DIMENSION SHEET

PD-255-L1

输入端/INPUT

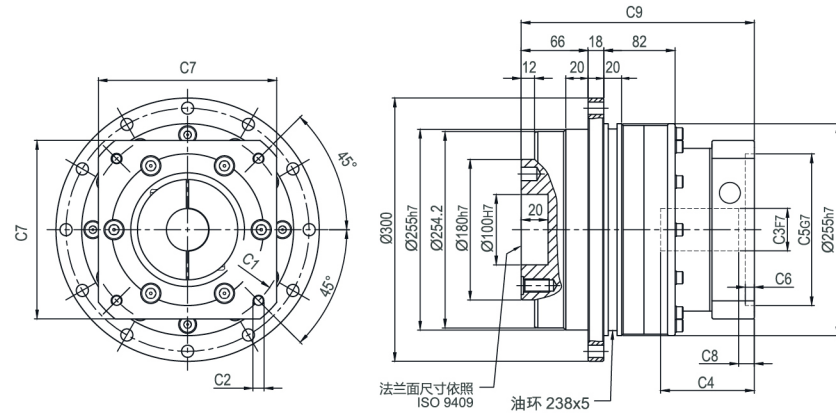

输出端/ OUTPUT

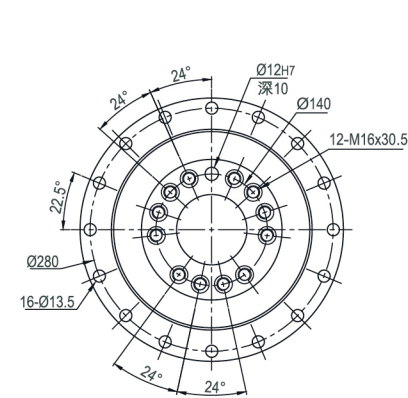

PD-255-L2

输入端/ INPUT

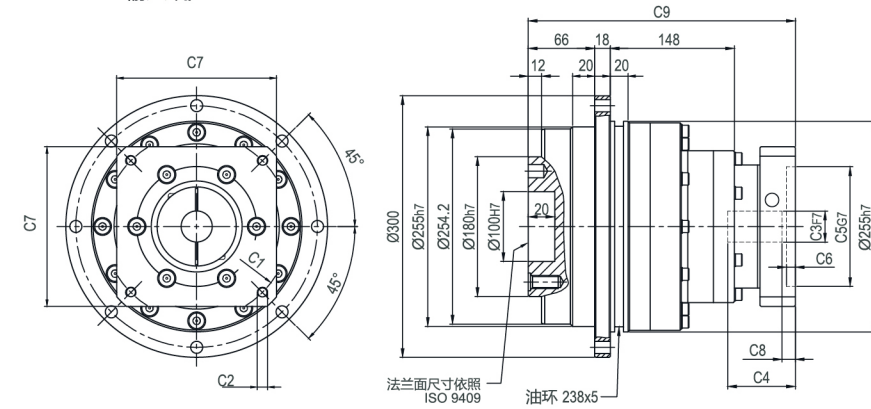

输出端/OUTPUT

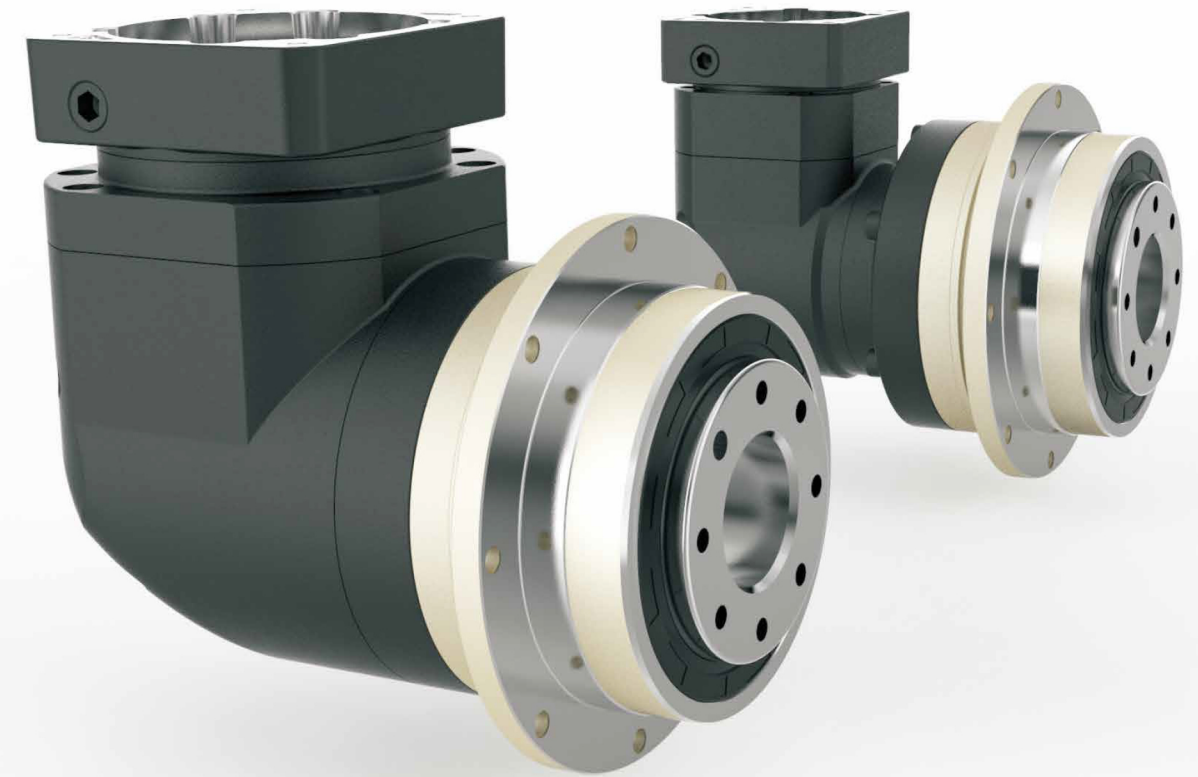
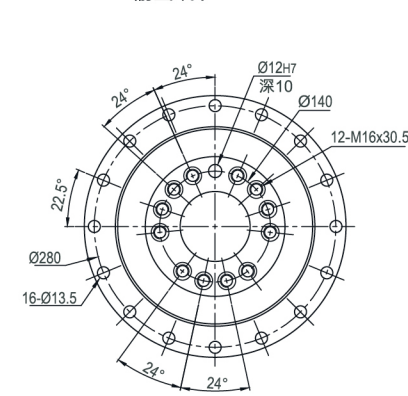

尺寸	C1	C2	C3	C4	C5	C6	C7	C8	C9
PD-255-L1	Ø235	4-M12x28	Ø38, Ø42	116	Ø200	6	220	10	256.5
PD-255-L2	Ø200	4-M12x28	Ø35	85	Ø114.3	6	180	10	311.5
	Ø215	4-M12x28	Ø38	85	Ø180	6	190	19	311.5

* C1~C7是公制标准马达连接板之尺寸,可根据客户要求单独定做。

* C1~C7are motor(metric standard) specific dimensions, which could be customised.

型号说明 / MODEL ILLUMINATE

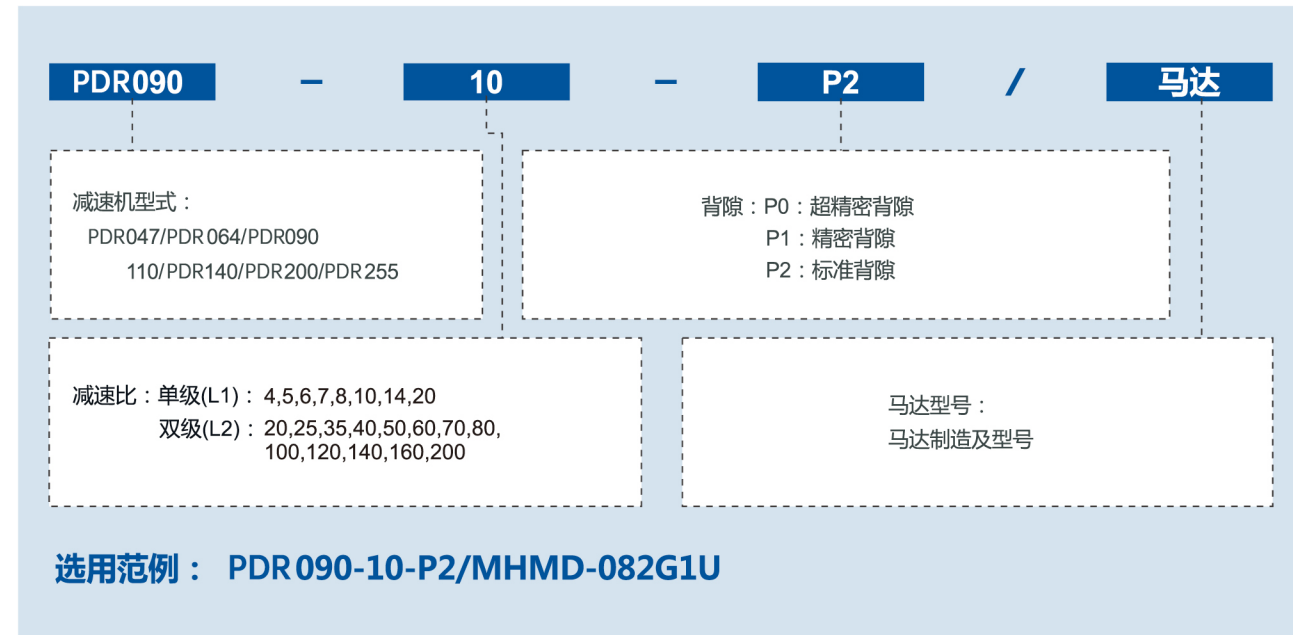

减速机性能资料/ GEAR BOX PERFORMANCE INFORMATION

规格	级数	减速比 ¹	PDR047	PDR064	PDR090	PDR110	PDR140	PDR200	PDR255	
额定输出力矩 T_{2N}	1	4	19	48	130	270	560	1,100	1,700	
		5	22	60	160	330	650	1,200	2,000	
		6	-	55	150	310	600	-	-	
		7	19	50	140	300	550	1,100	1,800	
		8	17	48	130	270	560	1,000	1,600	
		10	14	60	160	330	650	520	1,220	
		14	-	50	140	300	550	1,100	1,800	
		20	-	40	100	230	450	520	1,220	
		20	19	48	130	270	560	1,100	1,700	
		25	22	60	160	330	650	1,200	2,000	
	2	35	22	60	160	330	650	1,200	2,000	
		40	22	48	130	270	560	1,200	2,000	
		50	22	60	160	330	650	1,200	2,000	
		60	-	55	150	310	600	-	-	
		70	22	60	160	330	650	1,200	2,000	
		80	-	48	130	270	560	-	-	
		100	22	60	160	330	650	1,200	2,000	
		120	-	-	150	310	600	-	-	
		140	-	-	140	300	550	1,100	1,800	
		160	-	-	120	260	500	-	-	
200	-	-	100	230	450	520	1,220			
最大输出力矩 T_{2B}	Nm	1,2	3倍额定输出力矩							
额定输入转速 n_1	rpm	1,2	4~200	5,000	5,000	4,000	4,000	3,000	3,000	2,000
最大输入转速 n_{1B}	rpm	1,2	4~200	10,000	10,000	8,000	8,000	6,000	6,000	4,000
超精密背隙 P0	arcmin	1	4~20	-	-	≤2	≤2	≤2	≤2	≤2
		2	20~200	-	-	≤4	≤4	≤4	≤4	≤4
精密背隙 P1	arcmin	1	4~20	≤4	≤4	≤4	≤4	≤4	≤4	≤4
		2	20~200	≤7	≤7	≤7	≤7	≤7	≤7	≤7
标准背隙 P2	arcmin	1	4~20	≤6	≤6	≤6	≤6	≤6	≤6	≤6
		2	20~200	≤9	≤9	≤9	≤9	≤9	≤9	≤9
扭转刚性		1,2	4~200	7	13	31	82	151	440	1,006
最大弯曲力矩 M_{2KB}^2	Nm	1,2	4~200	42.5	125	235	430	1,300	3,064	5,900
容许径向力 F_{2B}^2	N	1,2	4~200	1,080	2,110	2,310	4,800	6,200	5,450	10,600
使用寿命	hr	1,2	4~200	20,000*						
效率 η	%	1	4~20	≥95%						
		2	20~200	≥92%						
重量	kg	1	4~20	1.1	2.1	5.9	10.5	21.9	50.9	85.4
		2	20~200	1.4	1.9	4.5	9.8	20.1	45.4	85.9
使用温度	°C	1,2	4~200	-10°C~+90°C						
润滑		1,2	4~200	合成润滑油脂						
防护等级		1,2	4~200	IP65						
安装方向		1,2	4~200	任意方向						
噪音值 ($n_1=3000rpm$)	dB	1,2	4~200	≤61	≤63	≤65	≤68	≤70	≤72	≤74

减速机转动惯量

规格	级数	减速比 ¹	PDR047	PDR064	PDR090	PDR110	PDR140	PDR200	PDR255
转动惯量 J_1	1	4~7	0.09	0.35	2.25	6.84	23.4	68.9	135.4
		8~10	0.09	0.07	1.87	6.25	21.8	65.6	119.8
		14~20	-	0.07	1.87	6.25	21.8	65.6	119.8
	2	20~40	0.09	0.09	0.35	2.25	6.84	23.4	68.9
		50	-	0.09	0.31	1.87	6.25	21.8	65.6
		60	-	0.09	0.35	2.25	6.84	-	-
		70~100	-	0.09	0.31	1.87	6.25	21.8	65.6
		120~200	-	-	0.31	1.87	6.25	21.8	65.6

1. 减速比 ($i=N_{in}/N_{out}$)
* 连续运转降低使用寿命二分之一。

2. 输出转速 100rpm 时, 作用于输出轴中心位置。

外形尺寸图表 / OUTLINE DIMENSION SHEET

PDR-090D(M1)-L1

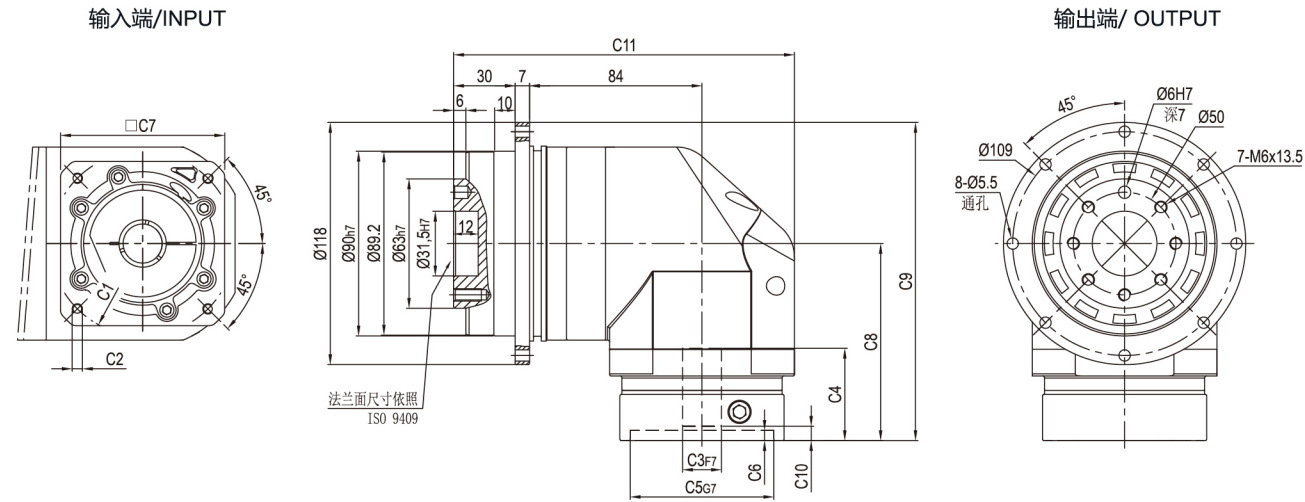

PDR-090D(M1)-L2

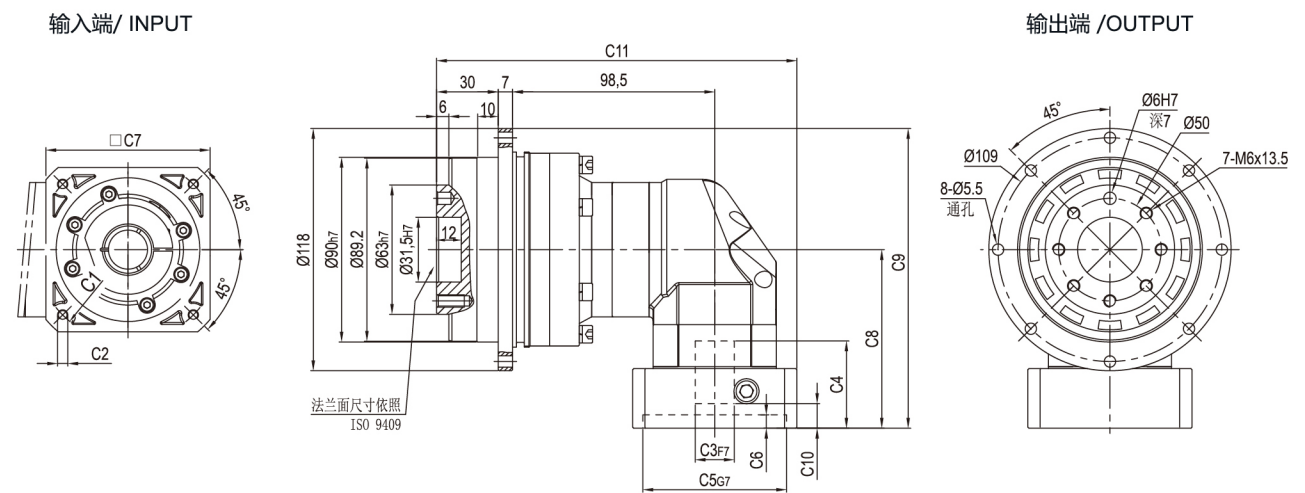

尺寸	C1	C2	C3	C4	C5	C6	C7	C8	C9	C10	C11
PDR-090D-L1	Ø90	4-M5x12,4-M6x14	Ø19	45	Ø70	6.5	80	96	155	7	166
	Ø100	4-M6x14	Ø16	45	Ø80	6.5	86	96	155	6	166
PDR-090M1-L1	Ø115	4-M8x20	Ø19,Ø22	56.5	Ø95	8	100	117.5	176.5	16.5	171
	Ø145	4-M8x20	Ø19,Ø22,Ø24	59	Ø110	11	130	120	179	19	186
PDR-090D-L2	Ø66.7	4-M4x10	Ø8	33	Ø38.1	5	60	77.5	136.5	5.5	165.5
	Ø70	4-M4x10,4-M5x12	Ø11,Ø14	33	Ø50	5	60	77.5	136.5	5.5	165.5
PDR-090M1-L2	Ø90	4-M5x12,4-M6x14	Ø19	42.5	Ø70	6.5	80	87	146	12	175.5
	Ø100	4-M6x14	Ø16	42.5	Ø80	6.5	86	87	146	11	175.5

* C1~C7是公制标准马达连接板之尺寸,可根据客户要求单独定做。
* C1~C7are motor(metric standard) specific dimensions, which could be customised.
* D:常规孔,M1:极限孔
* D: Conventional Hole, M1: Limit Hole

外形尺寸图表 / OUTLINE DIMENSION SHEET

PDR-110D(M1)-L1

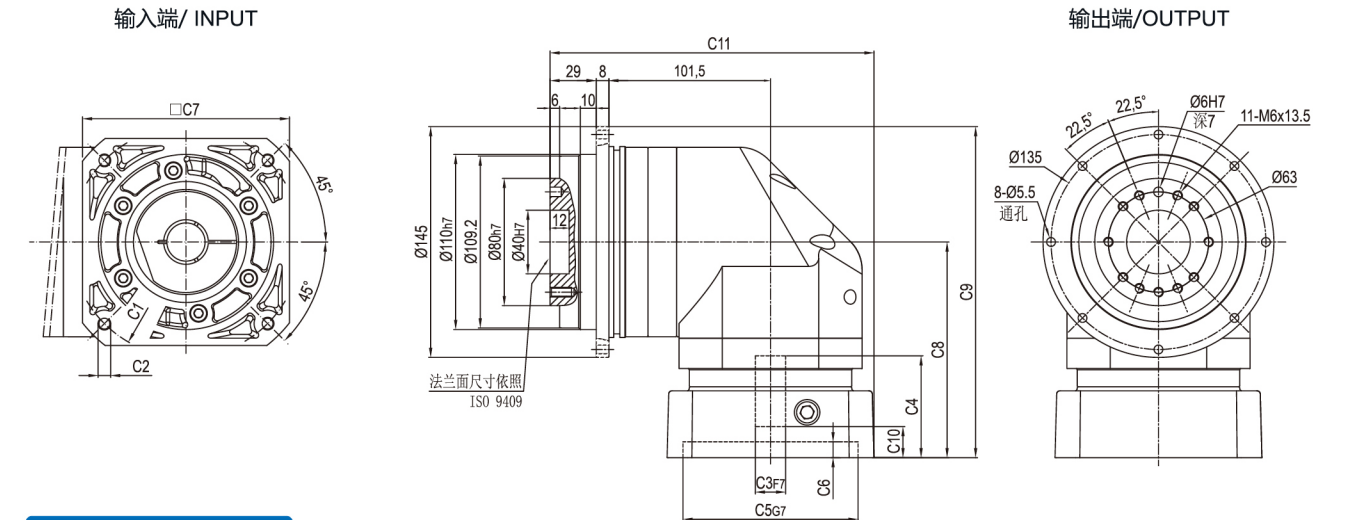

PDR-110D(M1)-L2

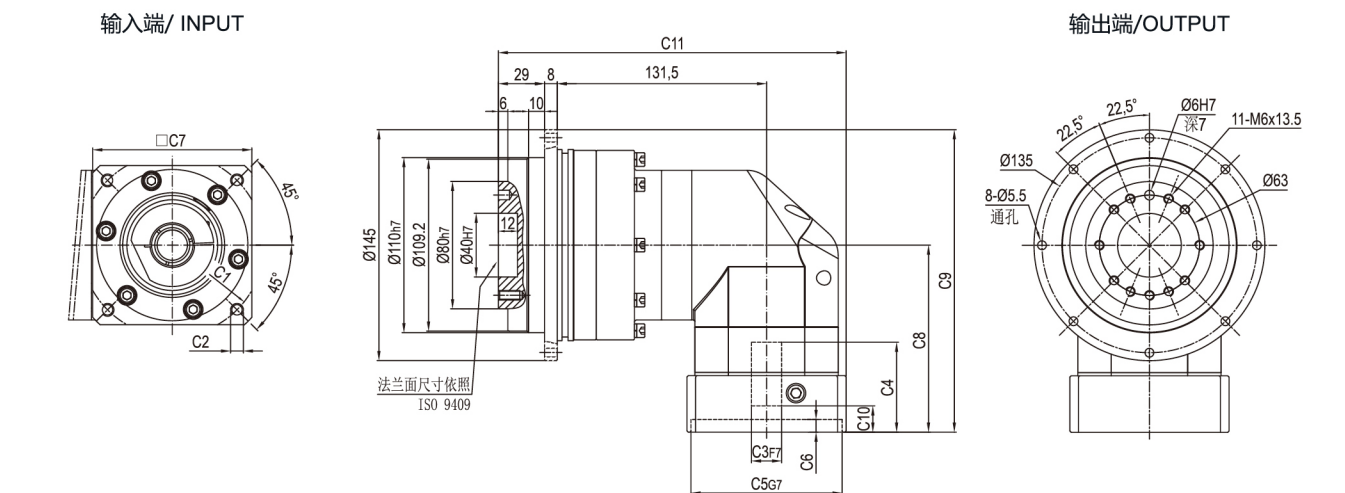

尺寸	C1	C2	C3	C4	C5	C6	C7	C8	C9	C10	C11
PDR-110D-L1	Ø145	4-M8x20	Ø19,Ø22,Ø24	64	Ø110	10	130	135.5	208	19.5	203.5
PDR-110M1-L1	Ø200	4-M12x28	Ø35	81	Ø114.3	10	180	152.5	225	28	228.5
PDR-110D-L2	Ø90	4-M5x12,4-M6x14	Ø19	45	Ø70	6.5	80	96	168.5	7	213.5
	Ø100	4-M6x14	Ø16	45	Ø80	6.5	86	96	168.5	6	213.5
PDR-110M1-L2	Ø115	4-M8x20	Ø19,Ø22	56.5	Ø95	8	100	117.5	190	16.5	218.5
	Ø145	4-M8x20	Ø19,Ø22,Ø24	59	Ø110	11	130	120	192.5	19	233.5

* C1~C7是公制标准马达连接板之尺寸,可根据客户要求单独定做。
* C1~C7are motor(metric standard) specific dimensions, which could be customised.
* D:常规孔,M1:极限孔
* D: Conventional Hole, M1: Limit Hole

外形尺寸图表 / OUTLINE DIMENSION SHEET

PDR-140D(M1)-L1

输入端/INPUT

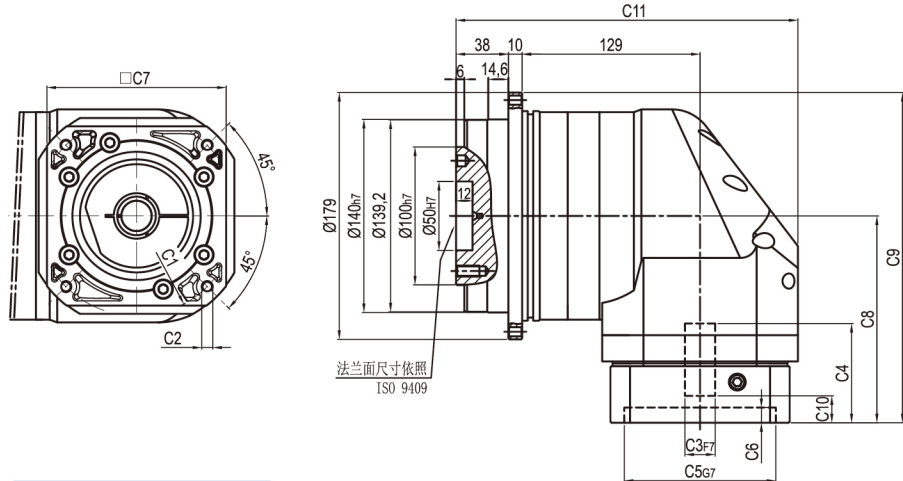

输出端/ OUTPUT

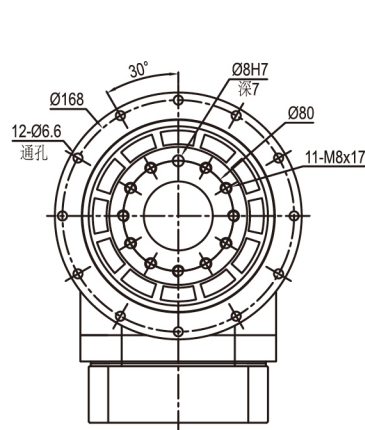

PDR-140D(M1)-L2

输入端/ INPUT

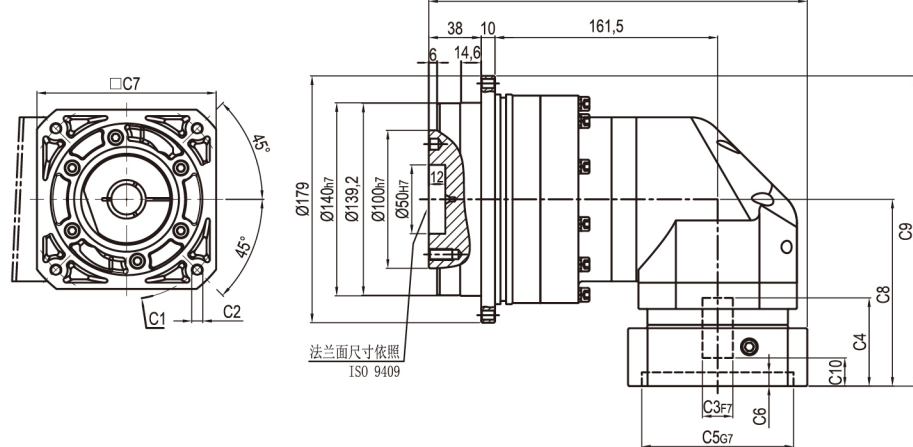

输出端 /OUTPUT

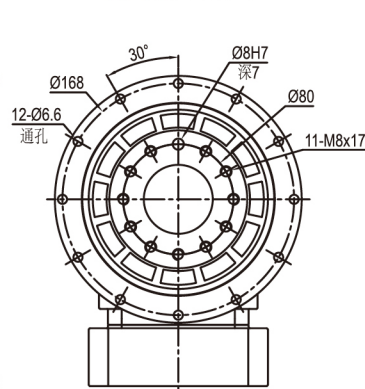

尺寸	C1	C2	C3	C4	C5	C6	C7	C8	C9	C10	C11
PDR-140D-L1	Ø145	4-M8x20	Ø22,Ø24	72	Ø110	11	130	150	239.5	19.5	248
	Ø200	4-M12x28	Ø35	82	Ø114.3	8	180	160	249.5	25	267
PDR-140D-L2	Ø145	4-M8x20	Ø19,Ø22,Ø24	64	Ø110	10	130	135.5	225	19.5	274.5
PDR-140M1-L2	Ø200	4-M12x28	Ø35	81	Ø114.3	10	180	152.5	242	28	299.5

- * C1~C7是公制标准马达连接板之尺寸,可根据客户要求单独定做。
- * C1~C7are motor(metric standard) specific dimensions, which could be customised.
- * D:常规孔,M1:极限孔
- * D: Conventional Hole, M1: Limit Hole

外形尺寸图表 / OUTLINE DIMENSION SHEET

PDR-200-L1

输入端/ INPUT

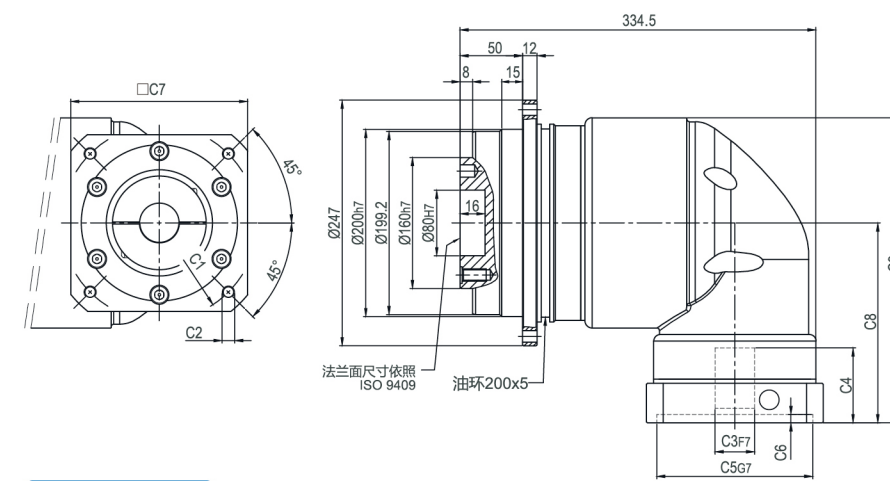

输出端/OUTPUT

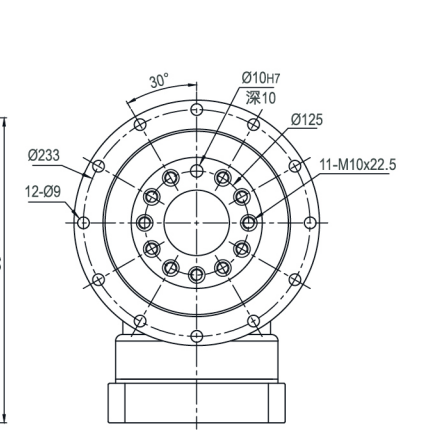

PDR-200-L2

输入端/ INPUT

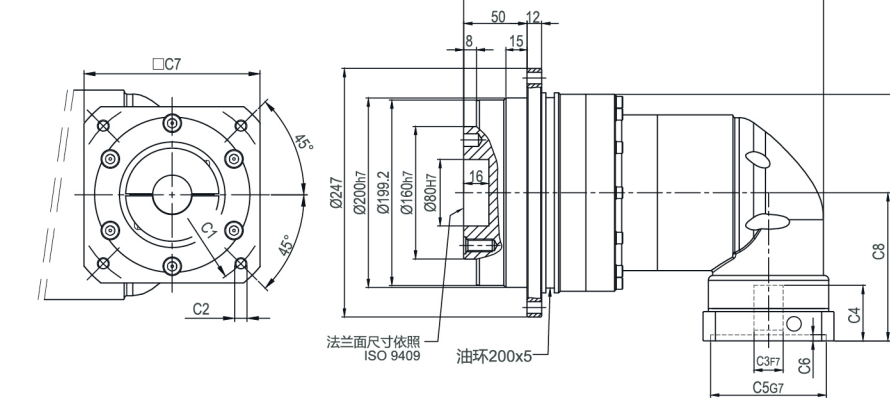

输出端/OUTPUT

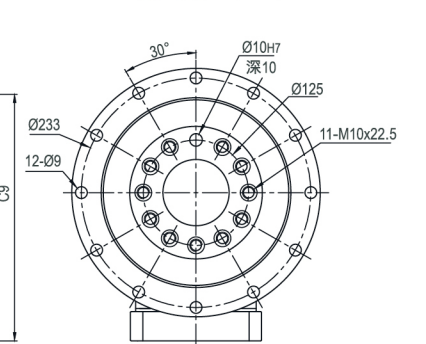

尺寸	C1	C2	C3	C4	C5	C6	C7	C8	C9
PDR-200-L1	Ø200	4-M12x28	Ø35	85	Ø114.3	6	180	213.5	316
	Ø215	4-M12x28	Ø38	85	Ø180	6	190	213.5	316
PDR-200-L2	Ø165	4-M10x25	Ø28	60	Ø130	6	142	164.5	269.5
	Ø200	4-M12x28	Ø35	85	Ø114.3	6	180	189.5	294.5

- * C1~C7是公制标准马达连接板之尺寸,可根据客户要求单独定做。
- * C1~C7are motor(metric standard) specific dimensions, which could be customised.